



**Portable and In-Ground Spas
Operating Manual**

Congratulations...

Congratulations...on becoming the owner of a Spa Industries Global Spa. You'll find the control systems in our spas have been designed for simplicity and can be programmed to suit your individual preferences.

With the proper care and service of your new spa, and the correct chemical maintenance of the water, your spa will provide years of enjoyment. Please take time to read this manual carefully before operating your spa.

Important.....

Do not power up your Spa until you have read this entire Operating Manual. Improper installation may result in equipment damage and void the Spa Warranty.

Contents

Spa Hardware Orientation	2
Warranty	3
Serial Number	4
Important Safety Instructions	5
Installation	
Preparing a foundation for Your Spa - Indoor/Outdoor Portables	6
Electrical Connections	7
- Requirements, Note To Electrician, Electrical Terminations	
Touchpad Control Centre	8
Checklist Prior To Filling Your Spa	9
Start-Up	11
Spa Maintenance	11
- Hygiene, Cleanliness, Chemical Management	
Spa Filters	12
- Cleaning Your Spa Filters	
- To Remove Cartridge Filter Elements	
- Replacing / Inserting Filters	
Draining The Spa	14
Acrylic Shell Maintenance	15
Spa Hardcover - Maintaining Your Spa Cover	15
Headrests - Removing Your Headrests	16
Lights	
- Underwater Light	16
- Portable Spa and Portable Swim Spa Back Load Model	
Jet Information	
Ozonator	17
Air Control, Aromatherapy Dispenser, Air Injectors	18
Jets	19 - 20
- Hurricane Jets, Mini Hurricane Jets, Micro Hurricane Jets	
- Cluster Jet	
Massage Selector / Diverter Valve	20
Blower & Pumps	21
Air Locks LF or DRY Messages	21
Trouble Shooting	22

Spa Hardware

Orientation

Touchpad Control Centre – located on the topside of your spa. This touchpad operates pump/s, blower, temperature adjustment and other ancillary functions that you may have, such as filter cycles, lights and diagnostic codes.



Control Box – where power supply, blower, ozone (if used) and circulation pump are connected. Located in the engine bay of your spa.



Main and Boost Pump (if applicable). Located in the engine bay of your Spa, this is the largest of the pumps in size and power. Used for creating water pressure through jets. Also used for filtration in the case of a 2-speed pumps option (refer to Controller Instructions).



Circulation Pump (if fitted) – located in the engine bay of your spa. This highly efficient, small power usage pump is used in the filtration and circulation of water through the heater.



Spa Hardware

Ozone (if fitted) – used for water purification. For additional chemical requirements when using ozone, contact your Authorised Dealer. There are two types of ozone units used in Spa Industries Global spas.

Heater – Housed with the control box.



Blower (if fitted) is located in the engine bay of the spa. Its purpose is to blow air through the air injector to create bubbles.



Aromatherapy Canister (if fitted) is located on the topside of the spa. This canister holds the Aroma Beads. To access the canister, unscrew the cap in an anti-clockwise direction. Ensure blower is not operational when removing cap.



General Information

Warranty

Your spa warranty covers the spa and associated equipment you have purchased. Please ensure you read and understand the Warranty and complete and forward any Warranty information to Spa Industries Global. Return of this information is critical in activating your Warranty.

Access

IMPORTANT NOTE: As stated in the Pre-Delivery Manual, when installing the spa, ensure there is 500mm unobstructed clearance around the entire perimeter of the spa. Ensure service access panels can be removed without obstruction. Failure to allow sufficient clearance may result in additional charges when servicing, general repairs or the need for warranty occurs.

Spa Serial Number

Your spa has its own serial number. This number will need to be quoted if warranty service is required. This number can be found in one of three places. It could be handy to write the serial number on this manual for future reference.

1. Specification Plate - Located above the spa controller within spa engine bay (Image A).
2. Name Plate - Located on the bottom of the spa frame on the Touchpad side (Image B).
3. Embedded in the outside edge of the spa shell flange on the left hand side on the opposite side to touchpad.



Identification / Compliance Label (Portable Spas and Swim Spas)

Spa Industries Global Portable Spas and Swim Spas come complete with their own Identification / Compliance Label which can be found in the engine bay area of the spa. It is an aluminium plate containing a host of information (pictured below in Image A).



Information will need to be given to the Authorised Spa Dealer when purchasing consumables (eg. filters or chemicals) or in the event of organising routine servicing of the spa or warranty requirements.

Inground model spas are engraved with a serial number located on the opposite side of the spa to the Touchpad, embedded in the outer acrylic surface of the spa.

A.

		Contact E-mail: service@spaindustries.com.au Post: P.O. Box 25, Hallam, 3803, VIC, Australia Approval No: V07929 IP Rating: IPX5			
Model: Cyclone Monsoon Advantage 13 - PS		Serial No: J000000			
Weight:	315	Dry (kg)	Options:	Light Ozone&Stereo	
	1715	Full (kg)		Litres:	1400
Power Supply:	1Ø	3Ø	Boost Pump:	4.0HP 1S X3	
	240	415	Circ Pump:	1/4HP X1	
	28		Controller:	COLOSSUS	
	38	N/A	Heater:	3 Kw	
		V (A.C. ± 5%) 50 Hz			
		A (Load Shed)			
		A (Full Load)			

B.

		Contact E-mail: service@spaindustries.com.au Post: P.O. Box 25, Hallam, 3803, VIC, Australia Approval No: V07929 IP Rating: IPX5			
Model: Cyclone Monsoon Advantage 13 - PS		Serial No: J000000			
Weight:	315	Dry (kg)	Options:	Light, Ozone & Stereo	
	1715	Full (kg)		Litres:	1400
Power Supply:	1Ø	3Ø	Boost Pump:	4.0HP 1S x3	
	240	415	Circ Pump:	1/4HP x1	
	28		Controller:	COLOSSUS	
	3Ø	N/A	Heater:	3 kW	
		V (a.c. ± 5%) 50 Hz			
		A (Load Shed)			
		A (Full Load)			

General Information

Important Safety Instructions

Do not power up your spa until you have read this entire Operating Manual. Improper installation may result in equipment damage and void the Spa Warranty.

Please take note:

- You must contact local Authorities in relation to pool fencing and other mandatory regulations that MUST be adhered to when installing a spa. Australia and New Zealand spas must comply with AS1926
 - A permit to fill your spa may be required from your local government department.
1. Do not use the spa while under the influence of drugs or alcohol, as they cause drowsiness and can result in drowning.
 2. Before entering the spa, the user should check the water temperature with an accurate thermometer. A temperature of 38°C is considered safe for a healthy adult. Special caution is suggested for young children.
 3. It is recommended that you use the spa for no longer than 15-20 minutes at a time.
 4. Do not put your head below water level.
 5. Consult a doctor before using the spa if taking any medication. Pregnant women should seek medical advice before entering a spa.
 6. Always disconnect spa from power supply before servicing your spa.
 7. Always supervise children using the spa.
 8. Do not use a spa that is not properly maintained and chemical balanced.
 9. Ensure all electrical connections meet the appropriate codes and standards.
 10. The spa is not intended for use by young children or infirm persons unless they have been adequately supervised by a responsible person to ensure that they can use the appliance safely.
 11. Young children should be supervised at all times whilst in and around the spa.

Note: All spas must be connected to a dedicated circuit protected by a safety switch and circuit breaker, and must comply with AS/NZ 3000.

Preparing A Foundation For Your Spa

Indoor / Outdoor

Your spa needs a good solid foundation. The area that your spa sits on must be able to support the weight of 500kg/m² (1000kg/m² for Swim Spas). If the foundation is inadequate, it may shift or settle after the spa is in place, causing stress to the shell.

Note: Damage caused by inadequate or improper foundation support is not covered by the Spa Warranty. It is the responsibility of the spa owner to provide a proper foundation for the spa. (please refer to paragraph below)

Place the spa on an elevated foundation so that water drains away from it. Proper drainage will keep components dry and protect them from continual damp conditions, and will also aid you when draining the spa for maintenance.

If you are installing your spa indoors, pay close attention to the flooring beneath it.

Always remember that the spa is filled with water. Choose flooring that will not be spoiled or ruined from water damage. Spa Industries Global will not accept responsibility for water damage caused through spa being placed in unacceptable surroundings.

If the spa is to be located on decking ensure the deck is capable of withstanding the combined weight mentioned above. It is recommended that a qualified contractor prepare the foundation for your spa. A base of 100mm (4inch) minimum concrete pad or equivalent is required to place your spa. If mounting on a deck centre supports must be installed to support the centre of the spa.

Electrical Connections

As stated in the Spa Industries Pre-Delivery Manual, a qualified Registered Electrical Contractor must undertake all electrical connections. You must also have a Certificate of Electrical Safety issued by the Electrical Contractor at completion of the installation. This certificate may need to be presented to your Authorised Spa Dealer or Spa Industries Global in the event of a warranty claim.

Requirements:

1. Extension cords are not to be used under any circumstances.
2. Ensure the power supply is correctly rated.
3. Ensure all electrical connections meet the appropriate codes and standards.
4. Keep electrical connections dry at all times.
5. A licensed electrician ONLY, must connect the power.
6. Ensure spa is connected on a dedicated circuit protected by a safety switch.
7. Ensure spa is permanently and reliably connected to the fixed wiring.
8. Spa should be supplied through a residual current device (RCD) with a rated tripping current not exceeding 30mA.
9. Parts containing live parts, except parts supplied with safety extra-low voltage not exceeding 12V, must be inaccessible to a person in the spa.
10. CAUTION: In order to avoid a hazard due to inadvertent resetting of the thermal cutout, the spa must not be supplied through an external switching device, such as a timer or connected to a circuit that is regularly switched on and off by the utility.

Note to the Electrician:

Drill appropriate size hole through base for cable and conduit entry. Ensure cables are fitted through base prior to filling with water.

Never rest spa on power cords.

Power Consumption

The power consumption of your spa can be found on the Identification / Compliance Label of your spa (read about in 'Identification / Compliance Label' section of this manual).

Power consumption is expressed in 'Full Load' and also 'Load Shed'

Full Load - is the maximum full load current draw of the spa.

Load Shed - is a feature of the Control System which by a minor setting change will cause the heater to shut down when the boost pump or blower is actuated. Hence the lower power consumption valve.

Directions on ascertaining this setting can be found on the back of the Control Box lid.

Power Consumption

Electrical Terminations

With all Spa Industries Global Spas, you will usually find the Control Box at the same end of the spa as the controller Touchpad Control Centre.

There are a number of electric controllers that you may find on your Spa Industries Global Spa. The GeckoSystem is the unit most widely used by Spa Industries Global. If it requires direct wiring the terminal connection can be found inside the Control Box.

The GeckoSystem has a Terminal Block in the control box similar to that in adjacent photo.

To gain entry to the Engine Bay, remove service access doors with Allenkey (supplied). The Engine Bay can be found below the Digital Touchpad Control Centre.

Be sure to take extreme care when connecting power cables to the unit, as incorrect connection can cause damage to the Control System.

Power supply to the spa needs to be on a dedicated circuit and be protected by a Residual Current Device (Safety Switch), as well as the correct size cable and circuit breaker protection.

In-ground spas are controlled from air buttons located on the topside of the spa. All electrical equipment must be located away from the spa itself. (The distance may vary, depending on the state and country codes and standards). Please read instructions supplied with the air switches in relation to mounting distance from the air buttons installed in the spa shell.

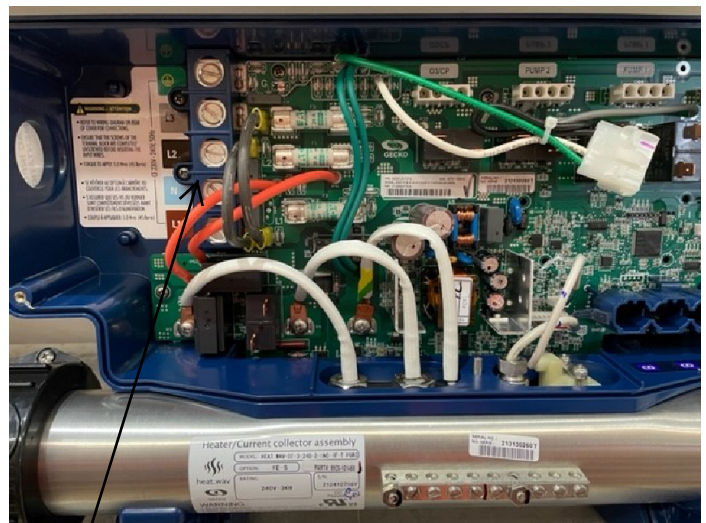

Terminal Block

Touchpad Control Centre (Portable Spas)

The spa is fitted with a Gecko Touchpad Control Centre. The instruction sheet for your Spa Control Centre will be supplied with your spa. The instruction sheet shows step by step operation procedures to operate pumps, blower, light (if applicable), ozone (if applicable) also for the control and setting of filter times and filter durations.

Checklist

Checklist Prior To Filling Your Spa

Never operate equipment without correct water in your spa. Serious damage to the pump and/or heater may occur. Damage caused to the pumps or heater through poor water chemistry will not be covered by the Spa Warranty.



- Remove all access service panels around the exterior of the spa, inspect for any item that may have come adrift or loosened during transport. Leave doors off until spa is filled with water and a check for leaks has been undertaken.

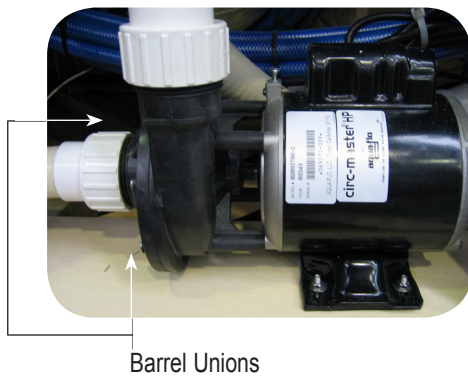

- Check barrel unions on all pumps and heaters to ensure they are tight; as they may loosen during transport.
They are not a Warranty item, and must be tightened prior to Start Up.



- Check external drain/fill valve (if installed) is closed and drain cap tight.

Checklist Prior To Filling Your Spa ...continued

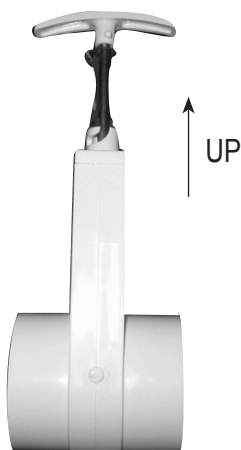

- Check shut-off valve. Valve (if installed) are located either side of the pump/s. The handles should be in the up position. This allows the water to travel through the pipes to your pump.
Note: The only time these are closed (down position) is during servicing.



- Fill your spa with clean water. Remove one filter and place hose directly into skimmer box to fill. This will help to alleviate air locks being created in the pumps or heaters. Fill until all jets are covered or at level shown on the skimmer/ filter box faceplate. Replace filter once correct water level is achieved. Make sure all jets are in the open position (Refer to Jet Section of this Operating Manual).
- Do not overfill the spa, as this can cause damage to the blower. Drain excess water if the bather load increases. Refill the spa after use. (Damage to the blower caused by water is not covered by Spa Warranty)
- Fit plastic locks to side of cabinet so as to hold the hard cover. (as per Hardcover Manufacturer's instructions.)
- Check for leaks around and under spa.

Start Up

- If spa is a plug-in model, plug the power cord into the power point and switch the power on. If the spa is hard wired, turn power on at the main isolator. When the unit is powered up, it is normal operation that the spa pumps may turn on and run for up to 4 minutes depending on the type of controller.
- Chemical addition. Contact your local Authorised Spa Dealer in relation to the best chemical selection for your spa.
- To heat your spa adjust the Temperature Button up, or to decrease heat simply adjust the Temperature Button down, depending on the model of the spa (Refer to your control instructions).
- Check for leaks, replace service access panels.

Note: Depending on water capacity, heater size and ambient temperature, it can take up to 12 hours to heat the spa to approximately 38°C. Swim Spas will take possibly twice as long.

Spa Maintenance

You are responsible for the maintenance of your spa.

Hygiene

The 'home' environment can affect the condition of your spa water. You should always shower prior to entering your spa. Good personal hygiene assists with water maintenance.

Our bodies need to adapt to the spa. Body oils will expel from your skin at a faster rate until your body adjusts to the spa environment. The same will occur when your friends come over to enjoy your new spa.

This may mean your filters will need cleaning more frequently in these instances.

Cleanliness

Your spa should be kept free from dirt and grit at all times. This will minimize the likelihood of particles being lodged in the jets or your spa's operating equipment.

It is wise to have a mat or foot wash near your spa, so that the spa users can wipe their feet before they enter the spa.

Dirt and grit in your plumbing system is not covered by Warranty, and can cause damage to your spa.

Chemical Management

It is extremely important to maintain your water chemistry of your spa, not only for health reasons, but also for the protection of spa components. The pH level should read between 7.2 and 7.8 to ensure clean water. The total alkalinity should read between 80 and 120 parts per million. Making sure all these requirements are correct will ensure your spa is clean and free of dirty water. If you don't maintain your water within these requirements you are risking voiding your Warranty as well as making your spa a breeding ground for disease. Your Authorised Spa Dealer can best guide you on the use of chemicals and what they would recommend.

Spa Filters

Cleaning Your Spa Filter Cartridges

Filter cartridges are made from fine polyester paper like material, specifically designed to filter out body oil and grime. Your spa is equipped with easy access skimmer cartridge filters. The average life expectancy of a filter cartridge is approximately 12-18 months, (with proper care and correct water maintenance).

It is recommended that the filters need to be cleaned every week to remove all body oils and grime from the surface (cleaning intervals dependent on usage)

Replacement filter cartridges may be purchased from your Authorised Spa Dealer. (It is recommended that you purchase a second set of filters.)

To Remove Cartridge Filter Elements

1. Turn power off to spa from circuit breaker or isolation switch.

Note: Ensure power is turned off during cleaning of filters as foreign matter can make its way into the pumps, heater and plumbing system while filters are removed.

2. Slide faceplate (1) upwards.
3. Slide filter basket (2) out.
4. Unscrew filter cartridges (3 & 4) (unscrew anti-clockwise) (Fig A)
5. Clean with the high-pressure nozzle to remove all debris clinging to the element.
6. Soak filter in a recommended Filter cartridge cleaner to remove all body oils and grime. Check with cartridge cleaner instructions.
7. Thoroughly rinse cartridge with clean water using a high-pressure nozzle again.
8. Replace filters - Be careful not to over tighten
9. Replace filter basket and faceplate

Note: Deep clean and soak the filter cartridges in special filter cleaners on a monthly basis, rotate with extra set of cartridges if possible. (Filter cleaner is available from your local Authorised Spa Dealer.)

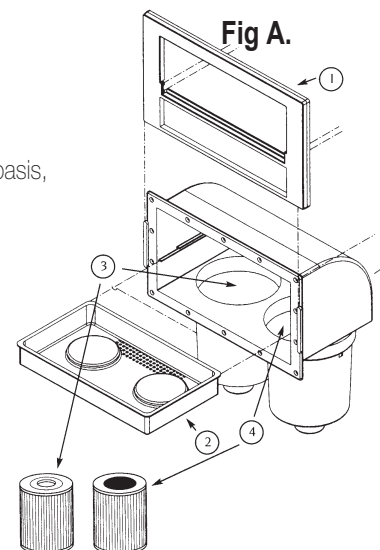

Spa Filters

To Remove Cartridge Filter Elements (Swim Spa)

Some Portable Swim Spas have 4 x 50sq/ft filter cartridges, place two on top of another (Fig B).

The cleaning process is conducted in exactly the same way as the Portable Spa except for the insertion of the filters (refer to replace / re-install filters).

Note: The washing of filters in water does not remove grease and grime, this must be removed by soaking the cartridges in Filter Cleaner.

Dirty or worn filters are the single biggest causes of spa malfunction.

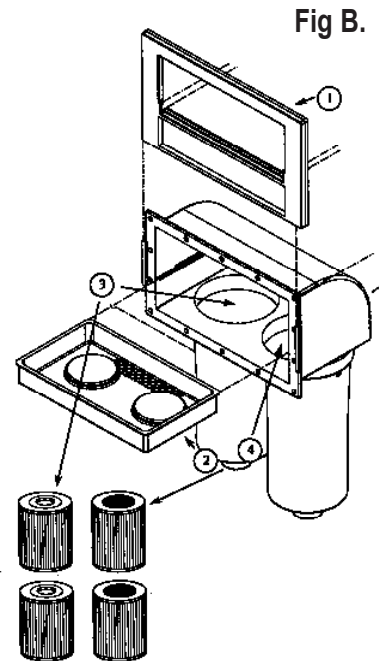

Top Loading Filters

For removal of top loading filter cartridges simply remove lid off skimmer enclosure and remove filter cartridges turning anti-clockwise.



Replacing / Inserting Filters

Prior to replacing filters in the spa following cleaning, thoroughly rinse cartridge to remove all soap residue (foaming may occur if not correctly rinsed).

When installing cartridge, submerge filter cartridge into the spa top first, to allow all trapped air to escape prior to inserting filter into Skimmer Box. (Fig C)

Failure to do this can induce an airlock into the plumbing system, this will cause the pump and heater to not operate correctly. To ensure there are no airlocks, simply loosen the barrel unions to the pump and heater to release any trapped air and then re-tighten. (when conducting the mentioned procedure ensure spa power is turned off.)

Be sure not to over tighten filter.

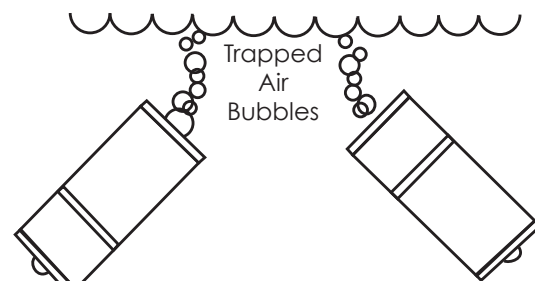

Fig C.

Draining the Spa

Approximately every 8-12 weeks, or more frequently depending upon usage, you should completely drain your spa.

About 1/3 of the water capacity should be drained off every month in addition to the above procedure to keep the water manageable.

The frequency of complete drainage depends on a number of variables including the amount of use, attention paid to water quality, maintenance etc. You will know it is time for a change, when you cannot control foaming and/or you can no longer get the normal feel or sparkle to the water even though the key water balance measurements are all within the proper parameters.

(if fitted) Your spa has a recessed external drain valve (Fig D), usually located on the front of the cabinet. This has been designed as the most practical and easiest way to empty your spa.

1. Isolate power at Circuit Breaker.
2. Remove center cap on drain and connect the supplied garden hose adaptor.
3. Turn the lock nut anti-clockwise and pull it out (10mm approximately) (Fig E). Allow the water to drain from the spa. This would generally take 5-6 hours to drain, so it is a good idea to let it drain overnight. Drain water to a suitable location
4. Use a bucket and a sponge to remove any remaining water from seats / foot well of spa.
5. After draining the spa remember to turn the drain valve to the off position.

Note: If draining for winter and the spa is going to be left empty for periods of time, loosen barrel unions to pump to remove all water from the plumbing system, and tighten once all the water is removed.

Make sure hardcover is put back over the spa as continuous direct sunlight can damage acrylic shell. Damage from UV or sunlight is not covered by Warranty.

Figure D.



Figure E.



Figure F.



Acrylic Shell Maintenance

Ensure spa is not continually exposed to the elements, the acrylic shell can reach very high temperatures if spa is located without shading or cover. Damage due to sunlight or extreme temperatures is not covered by the Spa Warranty. Exposure to the elements while not filled with water, while hardcover is removed or by simply no shading of the spa may cause damage to the acrylic shell.

With normal use of your spa, oils, lotions and hairsprays will build up on the surface of the water sometimes leaving a scum line around the perimeter of your spa shell.

Use a recommended cleaner or simply wipe down with a soft cloth and a non-abrasive cleaner. (eg methylated spirits). Clean while spa is drained for servicing or water change-over.

For hard water stains consult your Authorised Spa Dealer for an acceptable Spa cleaner/polish.

- Never allow your spa surface to come in contact with acetone (nail polish remover), nail polish, dry cleaning solution, lacquer thinners, gasoline, pine oil, abrasive cleaners, citrus cleaners or any other harsh chemical. These chemicals can damage your spa shell and void your Warranty.
- Do not use cleaning agents that will leave suds in your spa water.
- Adjustable jets should be removed and washed thoroughly to remove any dirt and grit build up. (Removal of jets is outlined in the 'jet' section)

Note: Minor scratches can be removed by using fine wet & dry sandpaper and car polish. Please consult your Authorised Spa Dealer before attempting this method.

Spa Hardcover

Using a Spa Hardcover any time when the spa is not in use will significantly reduce your operating costs, heat up time and maintenance requirements.

Getting The Most From Your Spa Cover

1. When cleaning your cover, use a mild soap and water.
2. Do not walk, jump or lie on cover.
3. When moving your cover, LIFT at all times, do not drag, drop or slide cover.
4. Do not lay cover on rough surfaces.
5. Approximately every four weeks, use a vinyl conditioner on top of the cover. Your Authorised Spa Dealer can best advise you of an appropriate cleaner.
6. Remove foam liner from Hardcover every 12 months and rotate to eliminate sagging of the Hardcover.

It is most important that you connect the lockdown clips to the cabinet, to ensure safety for your family.

Ensure hardcover is fitted on spa at all times when not in use.

Note: Damage to spa caused by the elements due to hardcover not being used correctly will void Warranty

Headrests

Removing Your Headrests

Most spa models have 2-7 moulded comfort pillows / headrests. These headrests are designed for comfort to the spa user.

We recommend removing these headrests periodically to clean behind them. We also recommend removing the headrests if your spa is not going to be used for a long period of time, as consistent exposure to chemicals, ozone and moisture may damage the product over time.

Every 3-6 months the headrests should be removed for cleaning. The headrests are secured to the shell by small snap in lugs, or are simply a slide fit, this prevents the headrest from falling into the spa.

Headrests can be wiped with methylated spirits, then coated with a high grade vinyl rejuvenator to rejuvenate the faded, powdered look.



Underwater Light

The light can be operated by the electronic touch pad. Your LED light has a number of colour sequences which are obtainable by simply toggling the light button, (on/off).

Portable Spa and Portable Swim Spa - Back Load Model

1. Isolate power for spa at circuit breaker.
2. Remove access panel behind where the light is situated.
3. Locate lamp holder with two (2) wires (black and white) entering the back of the light.
4. Remove lamp holder, by turning anti-clockwise with two (2) fingers only.
5. Replace faulty LED with new one.
6. Replace parts, including service access panel, restore power.



Jet Information

Ozonator

If fitted to your spa, the purpose of an Ozonator is to break down bacteria, yeast moulds and viruses leaving your spa water clear.

There are 2 types of ozone units which Spa Industries Global use:

1. 24hr Ozone, which as it states ozonates 24hrs a day.

The 24hr Ozone Generator pumps ozone into the Spa via a delivery head encasing a small blue stone mounted in a housing either in the bottom or side of the Spa shell.

For the ozone to operate the water level must be at correct operating level (refer to filling your spa). A small amount of sanitiser is required to be used with your ozone generator to help with water purification. Contact your local Authorised Spa Dealer for information on chemicals to be used in your spa.

This type of ozone generally has a blue stone that the ozone gas is injected through into the spa. Ozone takes the form of tiny air bubbles.

Should this flow of ozone reduce or stop you may need to remove the blue stone from delivery head and clean (eg: clean with steel wool). Stone must be repositioned into the delivery head prior to operating Spa.

2. The more widely used ozonator is the unit which ozonates during filter cycles.

If your Ozonator is in a cylindrical unit that operates on a venturi principle relying on water flow. The specially designed ozone jet is generally mounted in the footwell of your spa.

By simply removing the service access panel on the side of your spa you will be able to locate the ozone generator. When in operation the end of this type of generator will be illuminated and small ozone bubbles will be injected into your spa, as with the 24hr unit.

Depending on the concentration ozone has a scent ranging from a slightly sweet to moderately antiseptic smell.

If leaving spa without use for long periods of time remove headrests as prolonged exposure to chemicals may cause headrests to discolour.

Contact your Local Authorised Spa Dealer in relation to extra chemicals that may be used in conjunction ozone.

Jet Information

Air Control

These controls allow you to regulate the amount of air that is mixed with water entering through the jets. This significantly increases the jets performance and massage effect.

Air Control's should be in the closed position when spa is not in use, to aid in heat retention.



Aromatherapy Dispenser

On the lip of your spa there is a screw cap (if fitted), by adding specially formulated Aroma beads into the dispenser, beautiful scents are infused into the spa via the bubbles, enhancing relaxation and overcoming chemical smells. The scent is drawn into the water when the blower is activated.

When the scent becomes faint simply replace the Aroma beads, these can be purchased through your Authorised Spa Dealer.



Air Injectors

When the Blower button on the control pad is pressed, an air blower pumps air directly to individually plumbed air injectors located in the seats and foot well.

Air injectors further massage and caress your body.



Jet Information

Your new Spa has several different types of jets, with different massage actions. Follow the diagrams for correct operation of your jets.

Note: Turning off too many jets may cause water to syphon out of the Air Venturi's.

Hurricane Jets

The Large Hurricane Jets are interchangeable with each other. Move them around to suit your massage type.

Simply turn the jet clockwise / counter clockwise to turn water flow on /off.

To remove jet face, turn the jet face counter clockwise until the face clicks out.

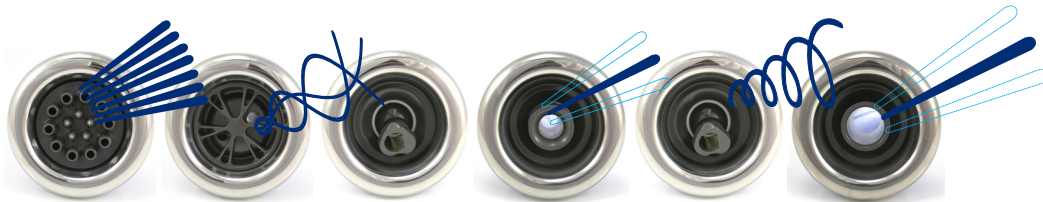

Mini Hurricane Jets

The Mini Hurricane Jets are interchangeable with each other. Move them around to suit your massage type.

Simply turn the jet clockwise/anti-clockwise to turn water flow on/off through the jet.

To remove jet face, turn jet face counter clockwise until the face clicks out.

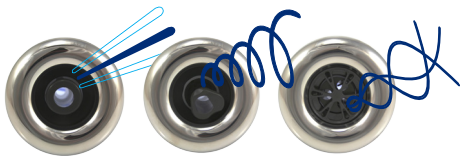

Micro Hurricane Jets

The Micro Jets are designed for a strong massage effect with a small jet face. (These jets are not able to be turned off).

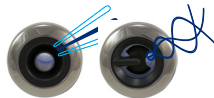

Jet Information

To keep your jets performing at their best, you should regularly remove adjustable jets and clean them (approximately once every 3 months).

Clean the jet face in hot soapy water. Make sure all fittings are moving freely before re-inserting. (Sand and grit in jet will not be covered by Warranty)

Ensure all soap residue is removed prior to re-installation of jet face.

If you are having trouble removing the jet face a tool can be purchased through your Authorised Spa Dealer.

Massage Selector / Diverter Valve

Some models are fitted with a Massage Selector or Diverter Valve. This valve is designed to change the flow of the water from one seat to another.

It is normally designed to divert the jets the following ways:

1. To the lounges/recliners (Position 1) or
2. To the hot seat in the corner (Position 2) or
3. The entire spa working simultaneously (Position 3)

Do not force the selector handle. If the handle becomes hard to turn, consult your Authorised Spa Dealer.

When heating the spa, leave the massage selector in (Position 1) to the Lounge area, or the hot seat area (Position 2). Do not leave selector valve in the center position (Position 3) with all the jets working, as the spa may not heat due to low flow at the heater.

Neck Jet Diverter:

If the Spa is fitted with reverse molded neck jets, a small diverter will be fitted adjacent the neck jets. Used to divert water to and from neck jets. This component serves purely as a diverter not an on / off control. When water is diverted away from neck jets a small amount of water may expell from the jets.

Position 3

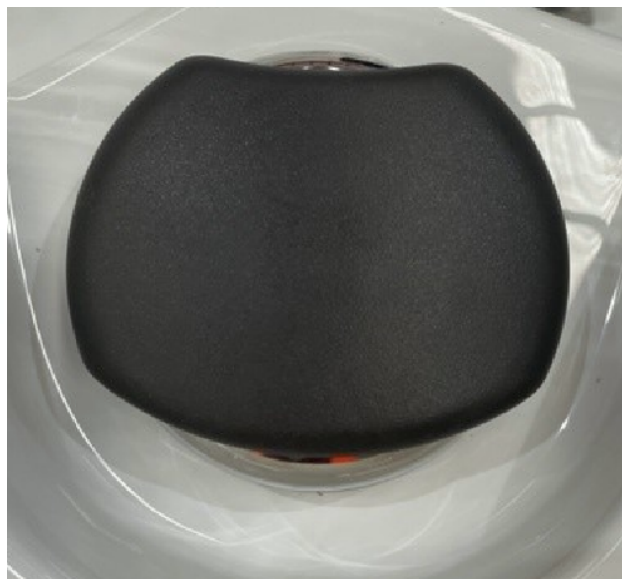

Position 2

Position 1

Blower & Pumps

The pump and/or blower will turn on automatically at various times of the day. This function is to eliminate the water becoming stagnant and allowing build up of bacteria.

The pumps and blowers will automatically turn off after approximately 20 minutes of operation. This is normal operation, designed to protect the pumps and blower.

If pumps and blower do not turn on, simply switch off power supply to the spa and then turn back on (portable spas only). During routine maintenance, it is important to ensure that the barrel unions to the pump are tight, as continued use may cause loosening through vibration.

Note: Pumps and Heaters:

Pumps and heater elements can be affected by corrosion if the balance of your water is not at the correct levels. You **MUST** maintain your total alkalinity and pH levels at the recommended levels at all times or you will void your Warranty on these items. Speak with your local Authorised Spa Dealer about Alkalinity and pH.

Air Locks LF or DRY Messages

Airlocks are a common cause of problems on initial start up of your spa or after reinstallation of filters after cleaning. When reinserting filter after cleaning please ensure the correct procedure is followed as set out in this manual (replacing / inserting filters).

The term LF, Dr or Dry means that the pump/heater on your spa creating the flow and filtering the water through the heater tube has an obstruction. Obstruction meaning dirty filters, a build up foreign matter on the suction side of the pump or an airlock.

Corrective action: if one of the above messages appears on the touch panel the following action is recommended:

Remove filters

Does message disappear

- | | |
|-----|-------------------------------------|
| Yes | Filters need cleaning or replacing. |
| No | See next step. |

Has Spa been left running while cleaning filters

- | | |
|-----|--|
| Yes | Probable blockage in pump. |
| No | Probable airlock in filtration system.
Isolate power to spa.
Loosen barrel union to filtration pump allow air to expel.
Should only be water escaping, no air.
Once all air is purged re-tighten barrel union to pump.
Reset power to spa.
If problem persists contact your Authorised Spa Dealer. |

Make sure when cleaning your filter cartridges that the power is isolated from your spa. If you continue to run the spa foreign matter can obstruct the operation of the pump.

Trouble Shooting

Problem	Cause	Procedure
Spa does not operate	<ol style="list-style-type: none"> 1. Power not connected 2. Power supply fault 	<ol style="list-style-type: none"> 1. Check power is connected 2. Check fuse or safety switch at meter box/switchboard
Power available, but pump Does not run	<ol style="list-style-type: none"> 1. Air lock in plumbing work 	<ol style="list-style-type: none"> 1. Loosen barrel union situated above pump to release build up of air. Release a small amount of water as well
Reduced water flow from jets	<ol style="list-style-type: none"> 1. Shut off valves, closed/off position 2. Insufficient water levels 3. No flow through jets 4. Pulsating jets 	<ol style="list-style-type: none"> 1. Open up the shut off gate valves to let water through 2. Add more water to Spa 3. Jets in off position, turn jet clockwise to on 3. Kink in delivery hose, remove access panel and check hoses 4. Check water level
Air blower not operating	<ol style="list-style-type: none"> 1. Blower not plugged in 	<ol style="list-style-type: none"> 1. Make sure blower plugged into socket on control box
Underwater light not operating	<ol style="list-style-type: none"> 1. Light not plugged in 2. Blown globe 	<ol style="list-style-type: none"> 1. Make sure light is plugged into power point or control box which ever is applicable 2. Replace globe
Spa will not heat	<ol style="list-style-type: none"> 1. Thermostat turned down low 2. Air blower on all the time 3. Excessive heat loss all the time 4. Filter cartridge dirty 5. Spa set on economy or sleep mode 	<ol style="list-style-type: none"> 1. Turn thermostat up to increase heat 2. Turn blower off, heating does not occur with blower load sharing 3. Fit hard cover to Spa 4. Clean cartridge 5. Increase time clock cycles or set to standard mode (as per controller instructions)
Spa turns on by itself	<ol style="list-style-type: none"> 1. Normal automatic daily Filtration or anti freeze cycle 	<ol style="list-style-type: none"> 1. No action required
Pump or Blower shuts off Unexpectedly while in use	<ol style="list-style-type: none"> 1. Automatic timer has shut pump off 2. Motor overheated and automatic protective device has shut down pump(s). 	<ol style="list-style-type: none"> 1. Push JETS button again down to start another cycle 2. Leave for 10 minutes push JETS button to restart

If any of the above procedures fail to rectify the listed problems, contact your local Authorised Spa Dealer for assistance.



SPA INDUSTRIES DEALER CONTACT